

低壓 **Class I/II Division 2** 防爆馬達 (NEMA)

**MODEL : AFHH**

STANDARD 3-PHASE HIGH EFFICIENCY INDUCTION MOTOR  
LOW VOLTAGE SQUIRREL CAGE  
FRAME SIZE (EG) 5009A~6808B



DWG NO.

**3A057M283E**

REV. 07

		<b>SPECIFICATION TABLE</b>	MODEL
		<b>3-PHASE HIGH EFFICIENCY INDUCTION MOTORS LOW VOLTAGE SQUIRREL CAGE</b>	<b>AFHH</b>
<b>ITEM</b>		<b>STANDARD SPECIFICATION</b>	
<b>RATING</b>	KIND OF MOTOR	SQUIRREL-CAGE INDUCTION MOTOR (SCIM), F3 FRAME	
	DESIGN STANDARD	NEMA MG-1, PREMIUM EFFICIENCY	
	VOLTAGE	460V, CAPABLE OF RUNNING ON 380V/50HZ ; 575V IS AVAILABLE	
	FREQUENCY	60Hz	
	OUTPUT RANGE	200 ~ 1000HP	
	R.P.M. (SYN.)	3600 ~ 900R.P.M. (2 ~ 8 POLE)	
	TIME DUTY	CONTINUOUS S.F. 1.15 (S1, MCR), RE-RATEABLE TO S.F. 1.0@50HZ VFD : CONTINUOUS S.F. 1.0 (S1, MCR)	
	FRAME SIZE (EG)	5009A ~ 6808B	
	PROTECTION ENCLOSURE	TOTALLY ENCLOSED (IP 55)	
	COOLING METHOD	SELF EXTERNAL FAN, SURFACE COOLING (IC 411)	
	MOUNTING	HORIZONTAL FOOT MOUNTING. F3 THROAT, F1 AS STANDARD WITH SWING ARM, F-2 AVAILABLE WITH SWING	
<b>APPLICATION</b>	POWER CONDITIONS	VOLTAGE : ±10%, FREQUENCY ±5%, AND 10% MAX. OF COMBINED VOLTAGE AND FREQUENCY	
	ENVIRONMENT CONDITIONS	PLACE : SHADOW, NON-HAZARDOUS CSA CLASS I DIV. 2, GROUP B, C & D, (OPTION) CSA CLASS II, DIV. 2, GROUP F&G, (OPTION) AMBIENT TEMPERATURE : -20 ~ 40°C RELATIVE HUMIDITY : LESS THAN 95%RH (NON-CONDENSATION) ALTITUDE : LESS THAN 3,300 FT	
	OPERATING CONDITIONS	DIRECT COUPLING SERVICE	
	DIRECTION OF ROTATING	BI-DIRECTIONAL, EXCEPT 2 POLE WHICH IS CLOCK-WISE FACING THE OPPOSITE DRIVE END	
	METHOD OF STARTING	FULL VOLTAGE DIRECT-ON-LINE OR Y - Δ STARTING OR VFD	
<b>CONSTRUCTION</b>	DIMENSIONS	AS DWG NO. 4B049R681~684E, 4B049R728~735E, 4B049R742~743E	
	FRAME	HIGH GRADE CAST IRON	
	END BRACKET (SHIELD)	HIGH GRADE CAST IRON	
	EXTERNAL FAN	ALUMINUM OR STEEL PLATE EXCEPT 2 POLE WHICH IS REINFORCED PLASTIC	
	FAN COVER (HOOD)	STEEL PLATE	
	SHAFT	CARBON STEEL, CYLINDRICAL SINGLE EXTENSION WITH KEYWAY AND KEY	
	BEARING	BRACKET MOUNTING, VACUUM DE-GASSED HIGH QUALITY ROLLING BEARINGS WITH REGREASE PROVISIONS. ALL MOTORS WITH DE BALL BEARINGS SUITABLE FOR DIRECT COUPLED APPLICATIONS MUST BE PROHIBITED FROM ANY AXIAL MOVEMENT OF THE DRIVE END BEARING AND ALL AXIAL THERMAL GROWTH MUST ALWAYS BE TOWARDS THE NON DRIVE END.	

# PERFORMANCE DATA

3-PHASE HIGH EFFICIENCY INDUCTION MOTORS  
LOW VOLTAGE SQUIRREL CAGE

MODEL  
**AFHH**  
460V 60Hz

TEFC, 2P 460V 60HZ

OUTPUT HP	FULL LOAD RPM	FRAME NO. (EG)	EFFICIENCY				POWER FACTOR			CURRENT			TORQUE		Safe Stall Time(s)		ROTOR WR <sup>2</sup> LB-FT <sup>2</sup>	Max. Load WR <sup>2</sup> LB-FT <sup>2</sup>	APPROX. WEIGHT LBS
			NOM.	MIN.	3/4	1/2	FULL	3/4	1/2	Rated	Starting	Starting	Starting	Max.	HOT	COLD			
			%	%	%	%	%	%	%	A	%	A	%	%	SEC	SEC			
350	3578	5009A	95.8	95.0	95.5	94.6	89.3	88.7	85.2	383	666	2550	120	220	23	31	53	284	3600
400	3579	5009A	95.8	95.0	95.6	94.8	89.7	89.1	85.7	436	665	2900	120	220	21	28	59	308	3700
450	3578	5009A	95.8	95.0	95.7	95.0	90.0	89.8	86.8	488	665	3250	120	220	21	27	65	355	3900
500	3577	5011A	95.8	95.0	95.7	95.1	90.4	90.3	87.6	541	670	3625	120	220	20	27	72	379	4300
600	3578	5011A	96.1	95.4	95.7	95.5	90.9	90.7	88.1	643	736	4730	120	220	18	24	88	450	4600
700	3580	5011A※	96.1	95.4	95.8	95.3	90.1	91.1	90.1	757	726	5500	120	220	15	23	92	497	4900
800	3585	5810A※	96.4	95.7	96.4	96.0	91.5	90.5	86.0	849	742	6300	120	230	19	25	187	568	6300

NOTE: 1 ACCORDING TO NEMA MG-1  
 2P: RATINGS 500HP AND BELOW ARE PREMIUM EFFICIENCY.  
 2 WITH "※" : COPPER ROTOR  
 3 WITHOUT "※" : ALUMINUM ROTOR  
 4 MULTIPLE MOUNTING DIMENSIONS FOR EACH FRAME NO.  
 FRAME 5009: MOUNTING HOLE WITH 5009 & 5007  
 FRAME 5011: MOUNTING HOLE WITH 5011, 5010 & 5009

TEFC, 4P 460V 60HZ

OUTPUT HP	FULL LOAD RPM	FRAME NO. (EG)	EFFICIENCY				POWER FACTOR			CURRENT			TORQUE		Safe Stall Time(s)		ROTOR WR <sup>2</sup> LB-FT <sup>2</sup>	Max. Load WR <sup>2</sup> LB-FT <sup>2</sup>	APPROX. WEIGHT LBS
			NOM.	MIN.	3/4	1/2	FULL	3/4	1/2	Rated	Starting	Starting	Starting	Max.	HOT SEC	COLD SEC			
			%	%	%	%	%	%	%	A	%	A	%	%					
350	1785	5009B	96.2	95.4	95.9	95.3	88.2	87.2	82.4	386	660	2550	95	200	12	18	138	1854	3700
400	1785	5009B	96.2	95.4	95.9	95.4	88.4	87.6	83.1	440	659	2900	95	210	12	19	155	2089	3900
450	1786	5009B	96.2	95.4	96.0	95.5	88.7	87.6	83.0	494	658	3250	100	210	11	18	176	2302	4100
500	1786	5011B	96.2	95.4	96.0	95.5	87.3	86.1	80.0	557	651	3625	100	210	13	20	200	2536	4500
600	1785	5011B	96.3	95.6	96.1	95.7	88.7	87.9	84.2	658	719	4730	100	210	17	22	231	2962	4800
700	1791	5011B※	96.5	95.8	96.3	95.9	87.8	86.4	81.2	774	711	5500	100	200	15	22	242	3389	5200
800	1787	5810B※	96.0	95.2	95.9	95.5	88.2	87.0	82.3	885	712	6300	95	200	11	17	356	3794	6600
900	1787	5810B※*	96.0	95.2	95.9	95.5	88.4	87.4	83.1	993	715	7100	95	200	10	15	403	4177	7000
1000	1786	5810B※*	96.0	95.2	95.9	95.5	88.1	87.6	83.8	1107	714	7900	95	200	26	31	403	4561	7000

NOTE: 1 ACCORDING TO NEMA MG-1  
 4P: RATINGS 500HP AND BELOW ARE PREMIUM EFFICIENCY.  
 2 WITH "※" : COPPER ROTOR  
 3 WITHOUT "※" : ALUMINUM ROTOR  
 4 MULTIPLE MOUNTING DIMENSIONS FOR EACH FRAME NO.  
 FRAME 5009: MOUNTING HOLE WITH 5009 & 5007  
 FRAME 5011: MOUNTING HOLE WITH 5011, 5010 & 5009  
 5 WITH " \* " : NO CSA CERTIFICATION. (4P 900, 1000HP)

TEFC, 6P 460V 60HZ

OUTPUT HP	FULL LOAD RPM	FRAME NO. (EG)	EFFICIENCY				POWER FACTOR			CURRENT			TORQUE		Safe Stall Time(s)		ROTOR WR <sup>2</sup> LB-FT <sup>2</sup>	Max. Load WR <sup>2</sup> LB-FT <sup>2</sup>	APPROX. WEIGHT LBS
			NOM.	MIN.	3/4	1/2	FULL	3/4	1/2	Rated	Starting	Starting	Starting	Max.	HOT	COLD			
			%	%	%	%	%	%	%	A	%	A	%	%	SEC	SEC			
300	1187	5009B	95.8	95.0	95.4	94.8	80.6	76.9	67.3	364	605	2200	100	200	15	19	153	5818	3900
350	1187	5009B	95.8	95.0	95.5	95.0	80.8	77.1	67.7	423	603	2550	110	200	14	18	177	6692	4100
400	1187	5011B	95.8	95.0	95.6	95.1	79.8	75.5	65.3	490	592	2900	110	200	13	17	205	7545	4600
450	1186	5011B	95.9	95.1	95.7	95.4	81.4	78.5	70.0	539	602	3250	110	200	14	18	229	8376	4800
500	1187	5011B	96.1	95.4	95.8	95.4	80.8	77.0	67.5	603	601	3625	110	200	12	16	253	9207	5000
600	1190	5011B※	96.4	95.7	96.0	95.7	84.5	82.1	74.3	689	686	4730	110	210	14	22	264	10827	5300
700	1188	5810B※	95.8	95.0	95.9	95.6	86.9	86.1	81.7	787	698	5500	95	200	17	25	385	12404	6300
800	1189	5810B※	96.0	95.2	96.0	95.7	86.9	85.7	80.4	898	702	6300	100	210	15	22	436	13938	6600
900	1189	5810B※*	96.0	95.2	96.1	95.8	87.4	86.4	81.9	1005	707	7100	100	210	16	22	516	15430	7200

NOTE: 1 ACCORDING TO NEMA MG-1  
 6P: RATINGS 350HP AND BELOW ARE PREMIUM EFFICIENCY.  
 2 WITH "※" : COPPER ROTOR  
 3 WITHOUT "※" : ALUMINUM ROTOR  
 4 MULTIPLE MOUNTING DIMENSIONS FOR EACH FRAME NO.  
 FRAME 5009: MOUNTING HOLE WITH 5009 & 5007  
 FRAME 5011: MOUNTING HOLE WITH 5011, 5010 & 5009  
 5 WITH " \* " : NO CSA CERTIFICATION. (6P 900HP)

TEFC, 8P 460V 60HZ

OUTPUT HP	FULL LOAD RPM	FRAME NO. (EG)	EFFICIENCY				POWER FACTOR			CURRENT			TORQUE		Safe Stall Time(s)		ROTOR WR <sup>2</sup> LB-FT <sup>2</sup>	Max. Load WR <sup>2</sup> LB-FT <sup>2</sup>	APPROX. WEIGHT LBS
			NOM.	MIN.	3/4	1/2	FULL	3/4	1/2	Rated	Starting	Starting	Starting	Max.	HOT SEC	COLD SEC			
			%	%	%	%	%	%	%	A	%	A	%	%					
200	890	5009B	94.5	93.6	94.2	93.6	79.4	76.2	66.9	250	581	1450	95	200	15	23	153	8099	3700
250	890	5009B	95.0	94.1	94.6	94.1	79.9	76.3	66.8	309	592	1825	100	200	14	22	186	9953	3900
300	889	5009B	95.0	94.1	94.8	94.4	81.1	78.4	70.1	365	603	2200	100	200	14	21	224	11743	4100
350	889	5009B	95.0	94.1	94.8	94.5	81.2	78.5	70.2	425	600	2550	100	200	13	21	258	13512	4300
400	890	5011B	95.1	94.2	94.9	94.6	80.9	77.5	68.5	487	596	2900	100	200	12	18	301	15260	4900
450	890	5011B	95.1	94.2	94.9	94.6	80.6	76.9	67.6	550	591	3250	100	210	13	20	339	16986	5100
500	890	5810B※	95.2	94.3	95.0	94.8	82.6	79.7	71.5	595	609	3625	95	200	15	23	437	18670	6600
600	891	5810B※	95.5	94.6	95.3	95.0	81.2	77.8	68.5	725	653	4730	95	200	22	29	445	21995	6700
700	891	5810B※	95.6	94.8	95.4	95.1	81.5	78.1	68.9	841	654	5500	95	200	23	28	517	25255	7200
800	893	6808B※	95.6	94.8	95.4	95.0	81.7	78.3	69.6	959	657	6300	100	200	24	31	1391	28431	8800
900	893	6808B※	95.8	95.0	95.4	95.0	82.5	79.6	71.6	1066	666	7100	100	200	24	30	1514	31543	9200

NOTE: 1 ACCORDING TO NEMA MG-1  
 8P: RATINGS 250HP AND BELOW ARE PREMIUM EFFICIENCY.  
 2 WITH "※" : COPPER ROTOR  
 3 WITHOUT "※" : ALUMINUM ROTOR  
 4 MULTIPLE MOUNTING DIMENSIONS FOR EACH FRAME NO.  
 FRAME 5009: MOUNTING HOLE WITH 5009 & 5007  
 FRAME 5011: MOUNTING HOLE WITH 5011, 5010 & 5009  
 5 WITH " \* " : NO CSA CERTIFICATION. (8P 900HP)

# OUTLINE DIMENSION SHEET

3-PHASE HIGH EFFICIENCY INDUCTION MOTOR  
FRAME SIZE (EG) 5810A

MODEL

**AFHH**

2P

TOTALLY ENCLOSED FAN COOLED TYPE. SQUIRREL CAGE ROTOR

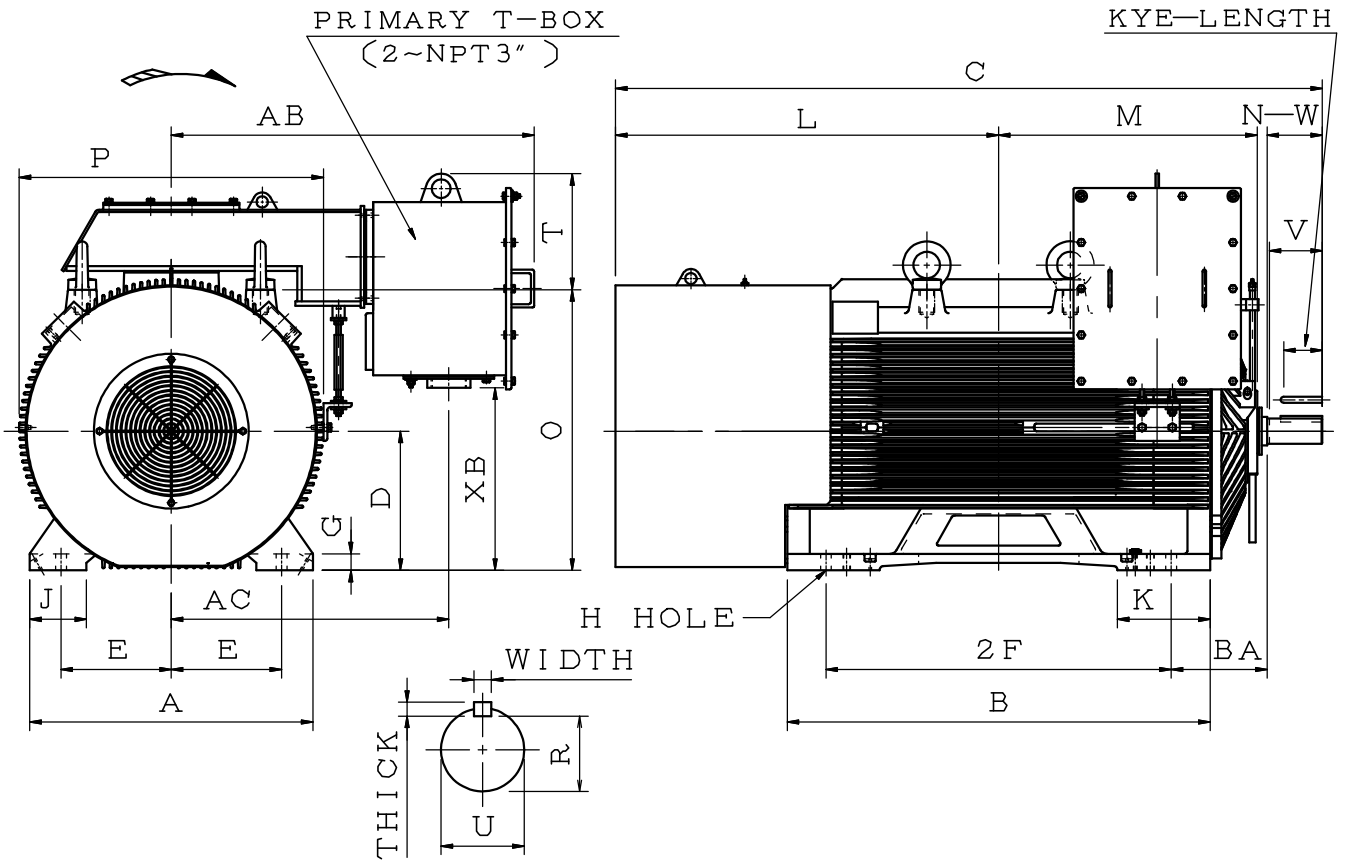

DIMENSIONS IN inches

FRAME SIZE (EG)	POLE	MOUNTING				A	B	C	D	G	J	K
		E	2F	H	BA							
5810A	2P	11.50	36.00	1.13	10.00	29.55	44.10	73.71	14.50	1.70	5.90	9.65
FRAME SIZE (EG)	L	M	O	P	T	KEY			KEYSEAT	TERMINAL HOUSING		
						WIDTH	THICK	LENGTH	R	AB	AC	XB
5810A	39.96	27.00	29.26	31.73	12.09	0.625	0.625	4.01	2.275	37.84	28.95	19.00
FRAME SIZE (EG)	SHAFT EXTENSION			BEARINGS								
	N-W	U	V	DRIVE END	OPP. DRIVE END							
5810A	5.75	2.625	5.50	6315C3	6315C3							

- NOTE: 1. DIMENSION D TOLERANCE: +0.00inch, -0.06inch  
 2. DIMENSION U TOLERANCE: +0.000inch, -0.001inch  
 3. DIMENSION R TOLERANCE: +0.000inch, -0.015inch  
 4. DIMENSION V IS THE LENGTH OF STRAIGHT PART OF SHAFT  
 5. FOR DIRECT FLEXIBLE COUPLING

# OUTLINE DIMENSION SHEET

3-PHASE HIGH EFFICIENCY INDUCTION MOTOR  
FRAME SIZE (EG) 5810B

MODEL

**AFHH**

4P, 6P, 8P

TOTALLY ENCLOSED FAN COOLED TYPE, SQUIRREL CAGE ROTOR

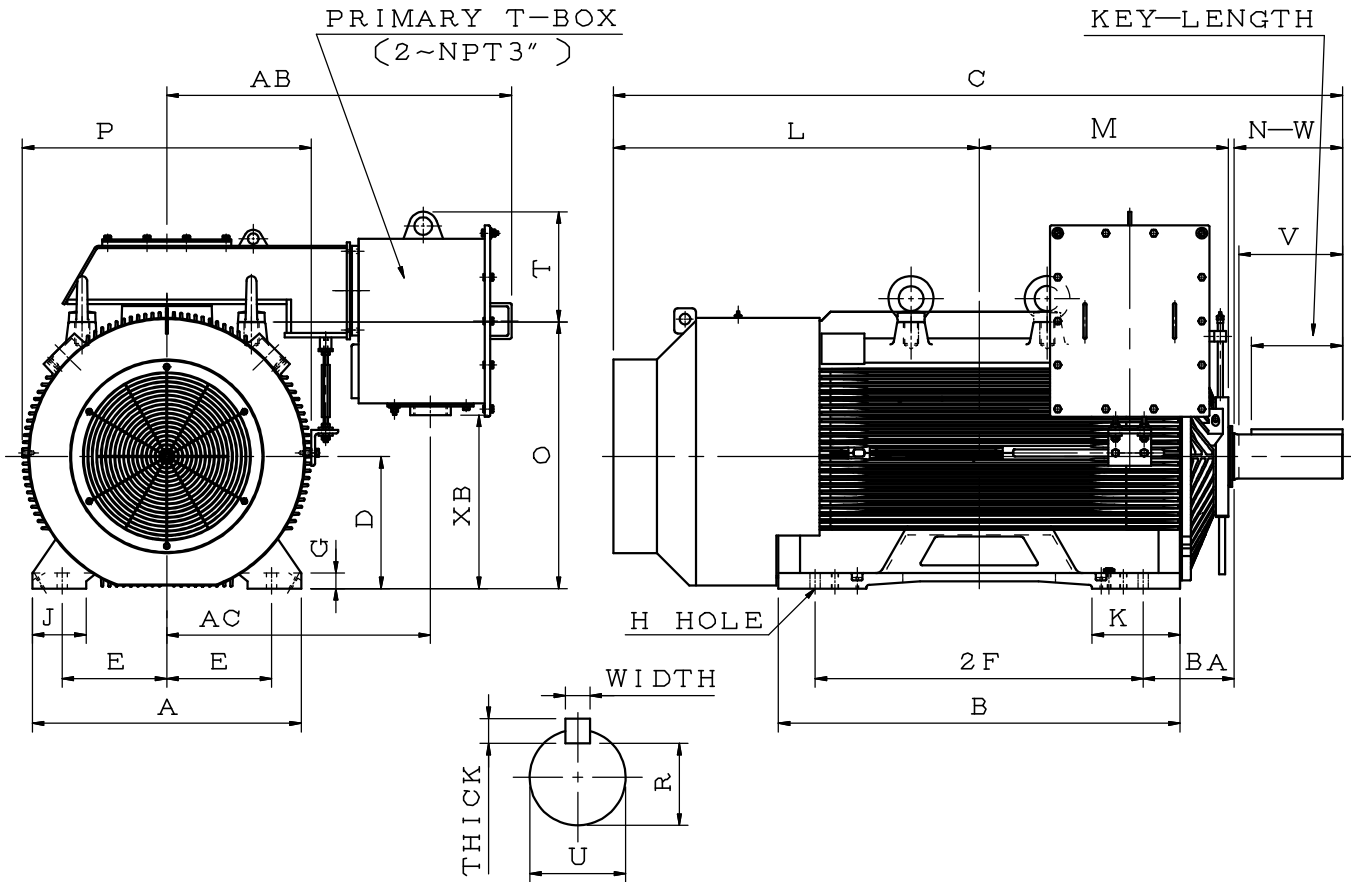

DIMENSIONS IN inches

FRAME SIZE (EG)	POLE	MOUNTING				A	B	C	D	G	J	K
		E	2F	H	BA							
5810B	4P~8P	11.50	36.00	1.13	10.00	29.55	44.10	79.25	14.50	1.70	5.90	9.65
FRAME SIZE (EG)	L	M	O	P	T	KEY			KEYSEAT	TERMINAL HOUSING		
						WIDTH	THICK	LENGTH	R	AB	AC	XB
5810B	39.37	27.17	29.26	31.73	12.09	1.250	1.250	10.00	4.169	37.84	28.95	19.00
FRAME SIZE (EG)	SHAFT EXTENSION			BEARINGS								
	N-W	U	V	DRIVE END	OPP. DRIVE END							
5810B	11.88	4.875	11.38	6326C3	6322C3							

- NOTE: 1. DIMENSION D TOLERANCE: +0.00inch, -0.06inch  
 2. DIMENSION U TOLERANCE: +0.000inch, -0.001inch  
 3. DIMENSION R TOLERANCE: +0.000inch, -0.015inch  
 4. DIMENSION V IS THE LENGTH OF STRAIGHT PART OF SHAFT  
 5. FOR DIRECT FLEXIBLE COUPLING



# OUTLINE DIMENSION SHEET

3-PHASE HIGH EFFICIENCY INDUCTION MOTOR  
FRAME SIZE (EG) 5009A

MODEL

**AFHH**

2P

TOTALLY ENCLOSED FAN COOLED TYPE, SQUIRREL CAGE ROTOR

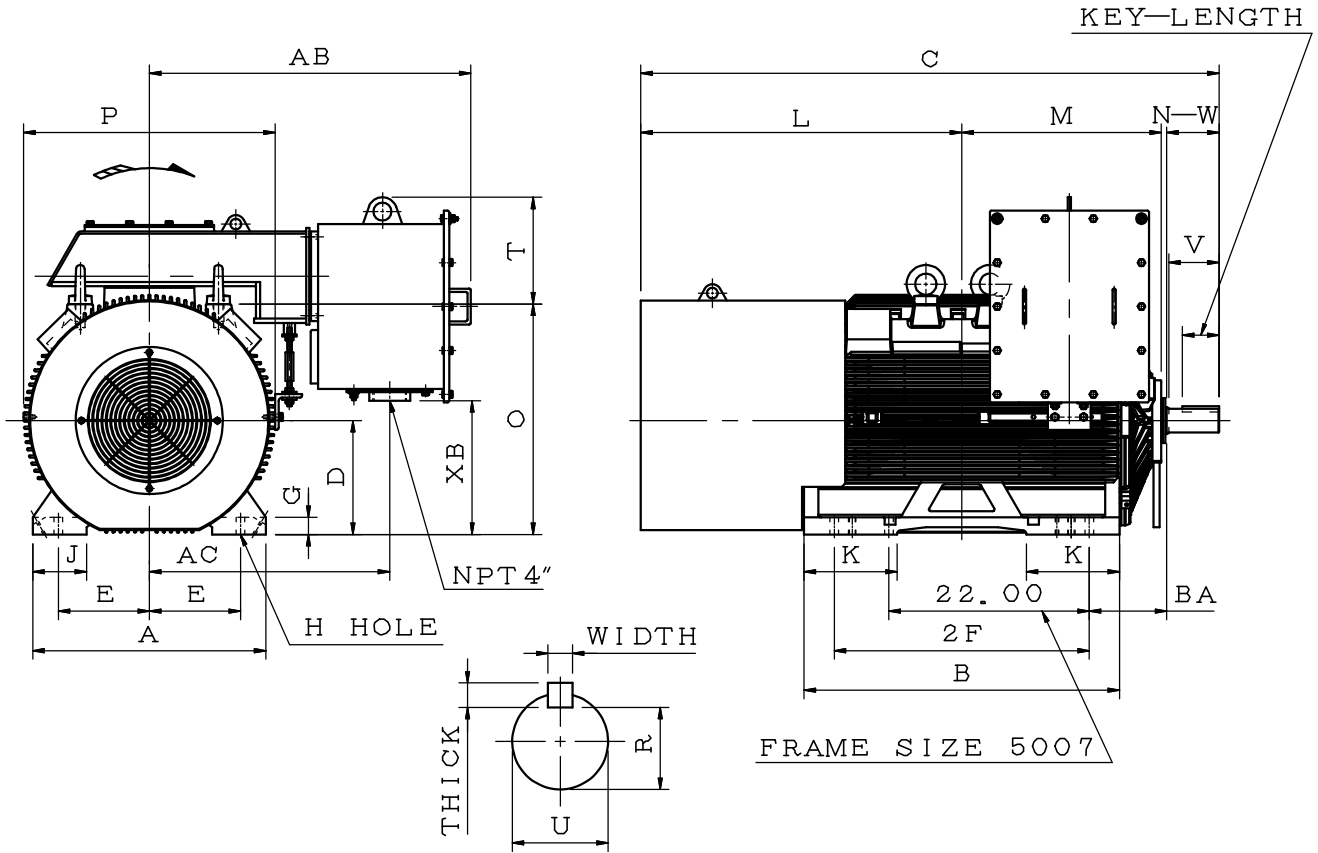

DIMENSIONS IN inches

FRAME SIZE (EG)	POLE	MOUNTING				A	B	C	D	G	J	K
		E	2F	H	BA							
5009A	2P	10.00	28.00	0.94	8.50	25.60	34.65	63.55	12.50	1.85	5.90	10.24
FRAME SIZE (EG)	L	M	O	P	T	KEY			KEYSEAT R	TERMINAL HOUSING		
						WIDTH	THICK	LENGTH		AB	AC	XB
5009A	35.24	21.89	25.30	27.60	11.71	0.625	0.625	4.01	2.275	35.28	26.40	14.70
FRAME SIZE (EG)	SHAFT EXTENSION			BEARINGS								
	N-W	U	V	DRIVE END	OPP. DRIVE END							
5009A	5.75	2.625	5.50	6315C3	6315C3							

- NOTE: 1. DIMENSION D TOLERANCE: +0.00inch, -0.06inch  
 2. DIMENSION U TOLERANCE: +0.000inch, -0.001inch  
 3. DIMENSION R TOLERANCE: +0.000inch, -0.015inch  
 4. DIMENSION V IS THE LENGTH OF STRAIGHT PART OF SHAFT  
 5. FOR DIRECT FLEXIBLE COUPLING

# OUTLINE DIMENSION SHEET

MODEL  
**AFHH**

3-PHASE HIGH EFFICIENCY INDUCTION MOTOR  
FRAME SIZE (EG) 5009B

4P~8P

TOTALLY ENCLOSED FAN COOLED TYPE, SQUIRREL CAGE ROTOR

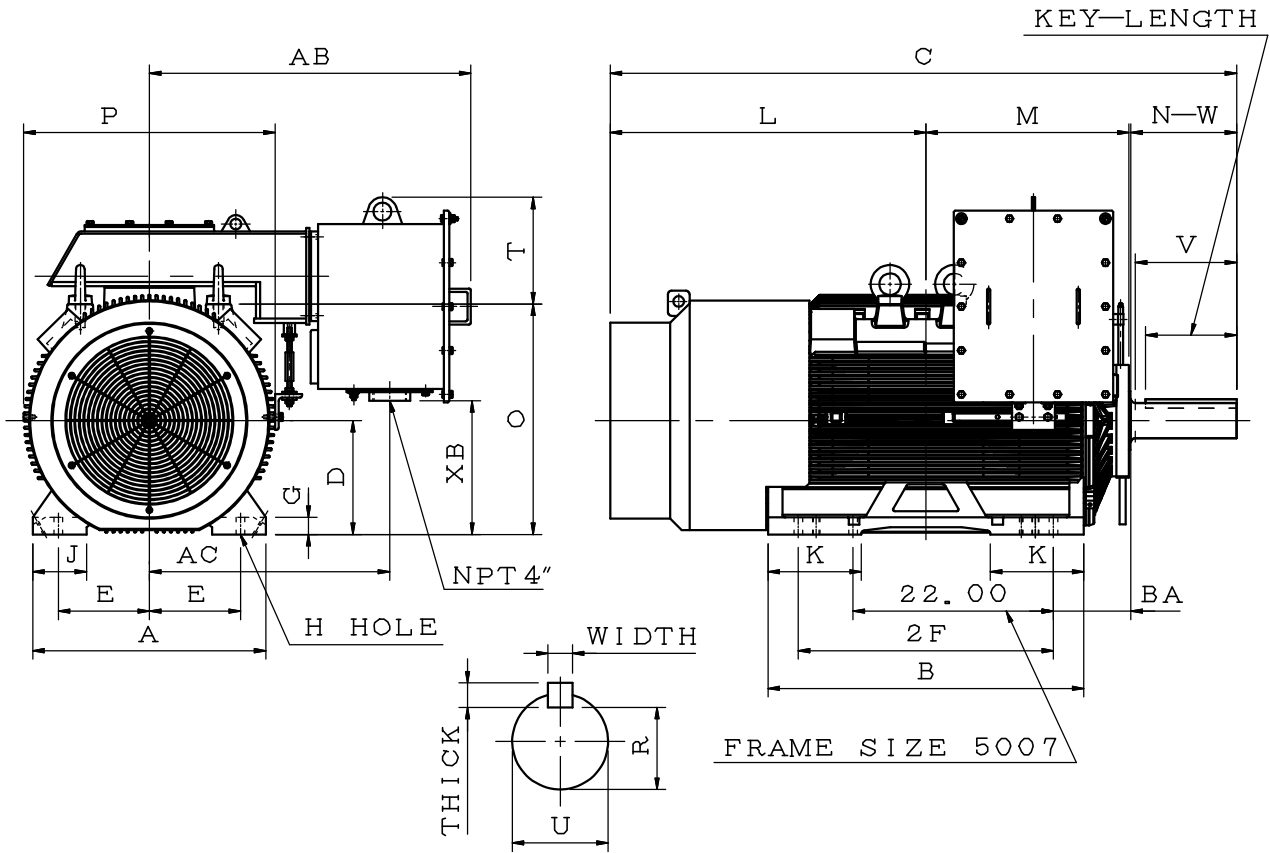

DIMENSIONS IN inches

FRAME SIZE (EG)	POLE	MOUNTING				A	B	C	D	G	J	K
		E	2F	H	BA							
5009B	4P~8P	10.00	28.00	0.94	8.50	25.60	34.65	68.83	12.50	1.85	5.90	10.24
FRAME SIZE (EG)	L	M	O	P	T	KEY			KEYSEAT R	TERMINAL HOUSING		
						WIDTH	THICK	LENGTH		AB	AC	XB
5009B	34.65	22.09	25.30	27.60	11.71	1.000	1.000	10.00	3.309	35.28	26.40	14.70
FRAME SIZE (EG)	SHAFT EXTENSION			BEARINGS								
	N-W	U	V	DRIVE END	OPP. DRIVE END							
5009B	11.62	3.875	11.12	6324C3	6320C3							

- NOTE: 1. DIMENSION D TOLERANCE: +0.00inch, -0.06inch  
 2. DIMENSION U TOLERANCE: +0.000inch, -0.001inch  
 3. DIMENSION R TOLERANCE: +0.000inch, -0.015inch  
 4. DIMENSION V IS THE LENGTH OF STRAIGHT PART OF SHAFT  
 5. FOR DIRECT FLEXIBLE COUPLING

# OUTLINE DIMENSION SHEET

3-PHASE HIGH EFFICIENCY INDUCTION MOTOR  
FRAME SIZE (EG) 5011A

MODEL

AFHH

2P

TOTALLY ENCLOSED FAN COOLED TYPE, SQUIRREL CAGE ROTOR

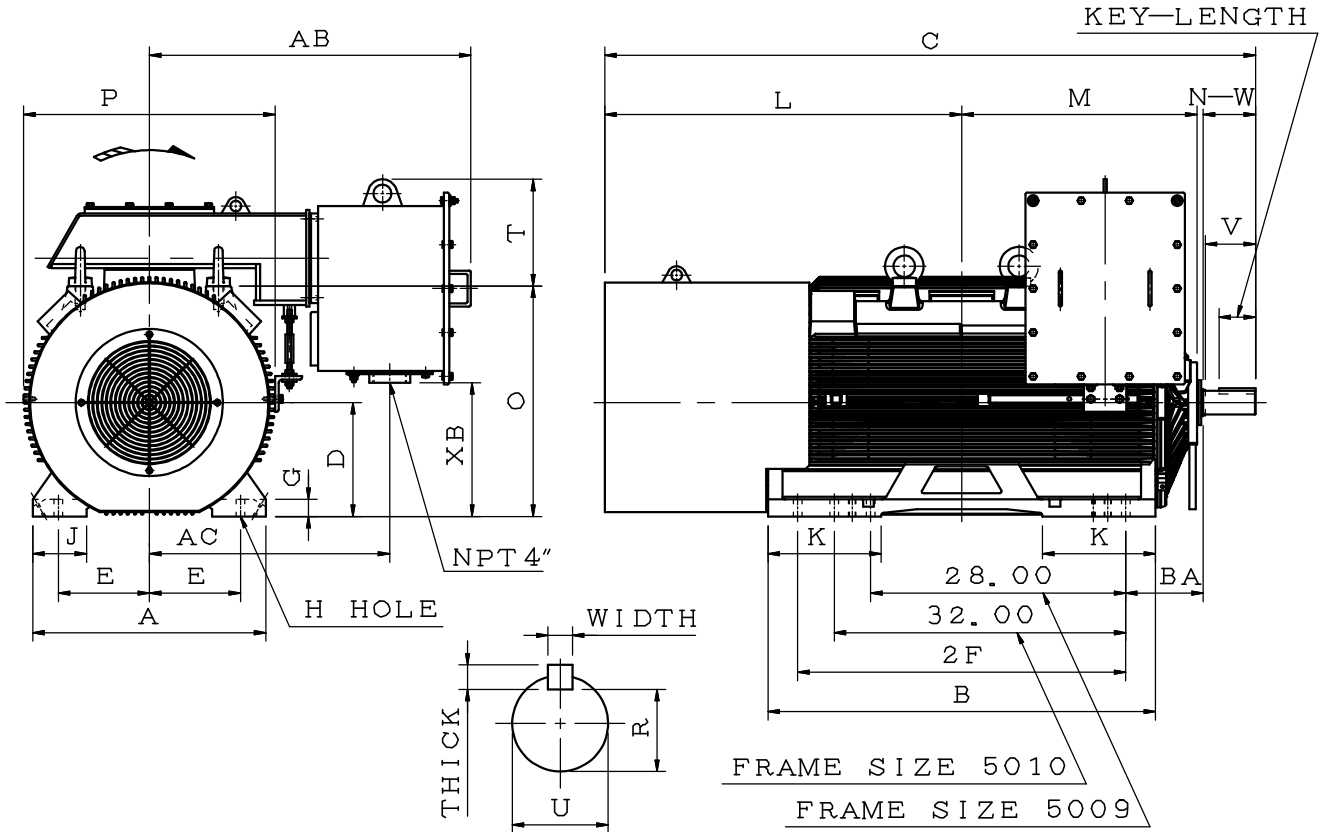

DIMENSIONS IN inches

FRAME SIZE (EG)	POLE	MOUNTING				A	B	C	D	G	J	K
		E	2F	H	BA							
5011A	2P	10.00	36.00	0.94	8.50	25.60	42.50	71.42	12.50	1.85	5.90	12.40
FRAME SIZE (EG)	L	M	O	P	T	KEY			KEYSEAT	TERMINAL HOUSING		
						WIDTH	THICK	LENGTH	R	AB	AC	XB
5011A	39.17	25.83	25.30	27.60	11.71	0.625	0.625	4.01	2.275	35.28	26.40	14.70
FRAME SIZE (EG)	SHAFT EXTENSION			BEARINGS								
	N-W	U	V	DRIVE END	OPP. DRIVE END							
5011A	5.75	2.625	5.50	6315C3	6315C3							

- NOTE: 1. DIMENSION D TOLERANCE: +0.00inch, -0.06inch  
 2. DIMENSION U TOLERANCE: +0.000inch, -0.001inch  
 3. DIMENSION R TOLERANCE: +0.000inch, -0.015inch  
 4. DIMENSION V IS THE LENGTH OF STRAIGHT PART OF SHAFT  
 5. FOR DIRECT FLEXIBLE COUPLING

# OUTLINE DIMENSION SHEET

3-PHASE HIGH EFFICIENCY INDUCTION MOTOR  
FRAME SIZE (EG) 5011B

MODEL

**AFHH**

4P~8P

TOTALLY ENCLOSED FAN COOLED TYPE, SQUIRREL CAGE ROTOR

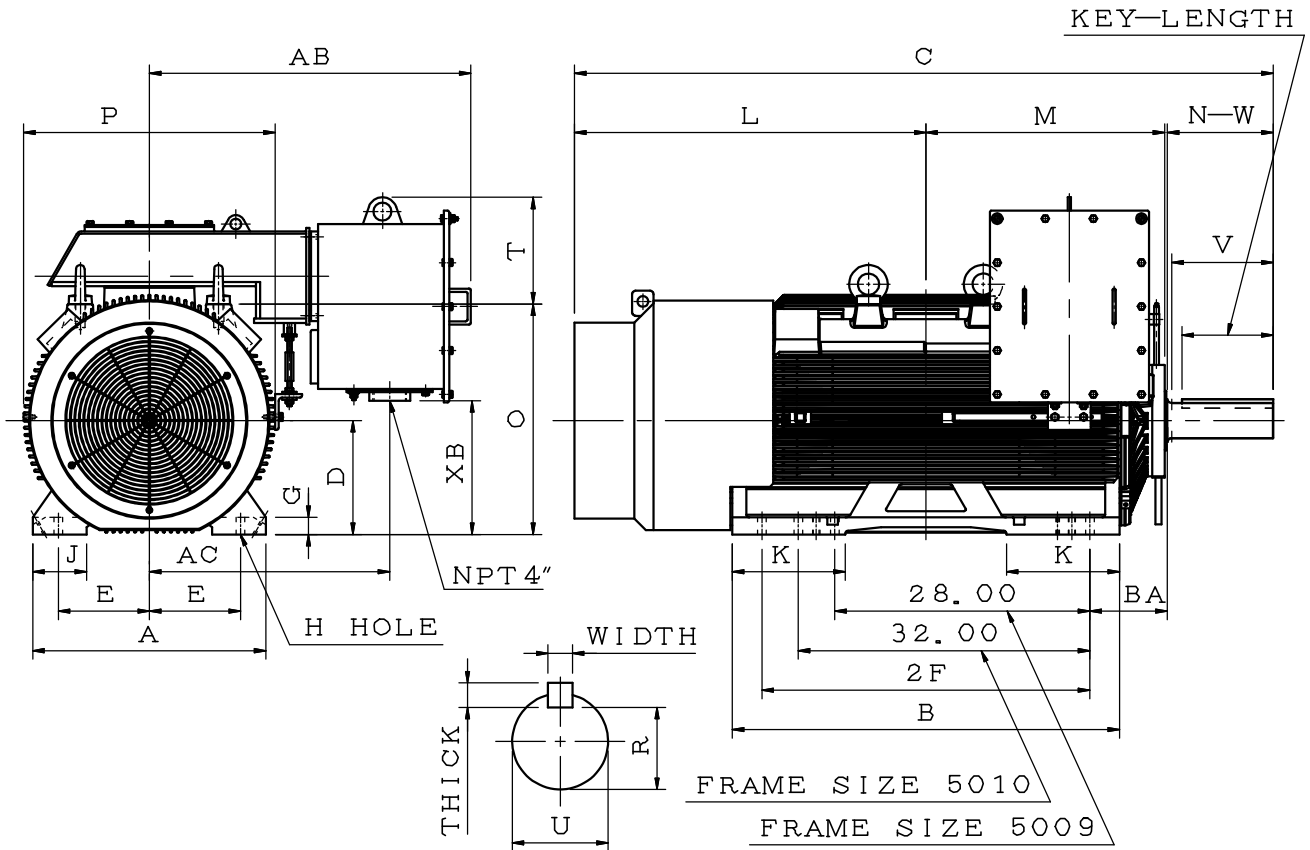

DIMENSIONS IN inches

FRAME SIZE (EG)	POLE	MOUNTING				A	B	C	D	G	J	K
		E	2F	H	BA							
5011B	4P~8P	10.00	36.00	0.94	8.50	25.60	42.50	76.70	12.50	1.85	5.90	12.40
FRAME SIZE (EG)	L	M	O	P	T	KEY			KEYSEAT	TERMINAL HOUSING		
						WIDTH	THICK	LENGTH	R	AB	AC	XB
5011B	38.58	26.02	25.30	27.60	11.71	1.000	1.000	10.00	3.309	35.28	26.40	14.70
FRAME SIZE (EG)	SHAFT EXTENSION			BEARINGS								
	N-W	U	V	DRIVE END	OPP. DRIVE END							
5011B	11.62	3.875	11.12	6324C3	6320C3							

- NOTE: 1. DIMENSION D TOLERANCE: +0.00inch, -0.06inch  
 2. DIMENSION U TOLERANCE: +0.000inch, -0.001inch  
 3. DIMENSION R TOLERANCE: +0.000inch, -0.015inch  
 4. DIMENSION V IS THE LENGTH OF STRAIGHT PART OF SHAFT  
 5. FOR DIRECT FLEXIBLE COUPLING

# OUTLINE DIMENSION SHEET

3-PHASE HIGH EFFICIENCY INDUCTION MOTOR  
FRAME SIZE (EG) 6808B

MODEL

**AFHH**

8P

TOTALLY ENCLOSED FAN COOLED TYPE, SQUIRREL CAGE ROTOR

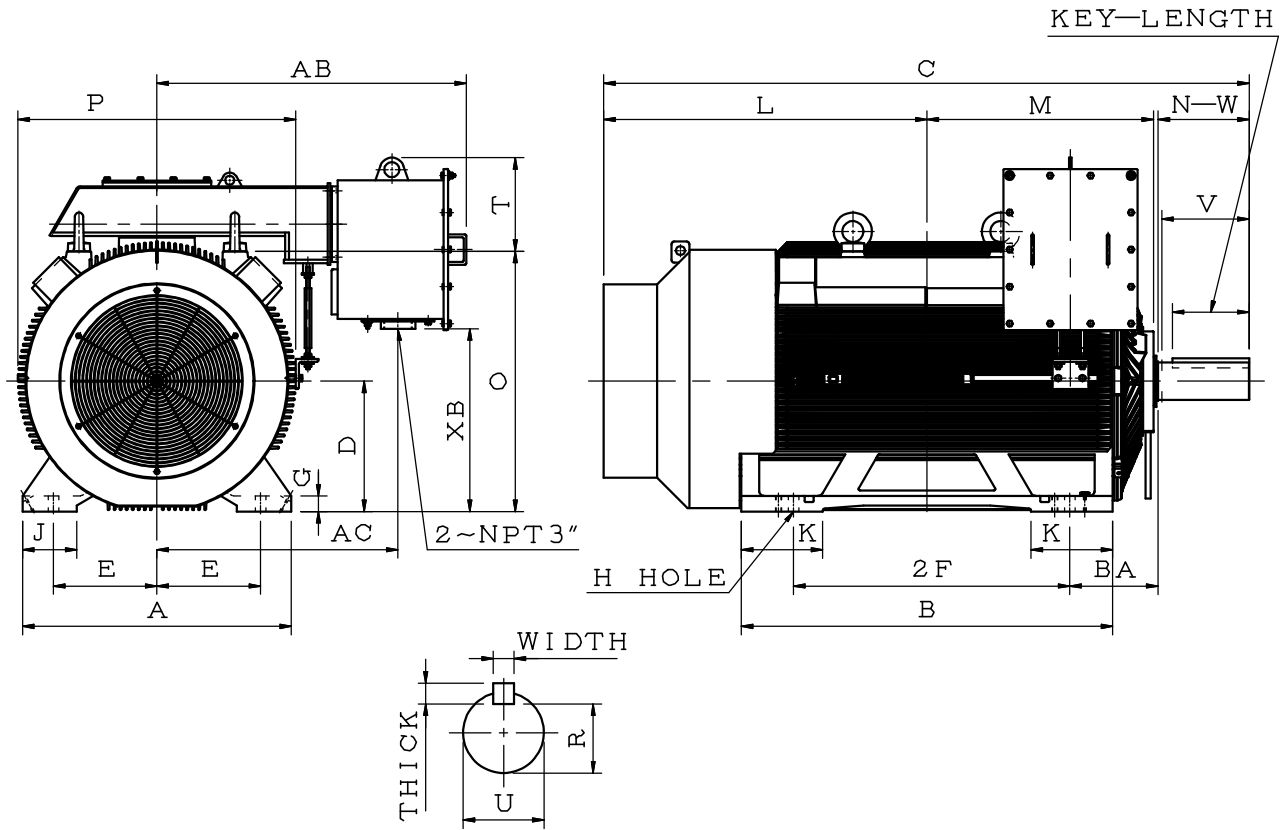

DIMENSIONS IN inches

FRAME SIZE (EG)	POLE	MOUNTING				A	B	C	D	G	J	K
		E	2F	H	BA							
6808B	8P	13.50	36.00	1.38	11.50	35.00	48.45	84.12	17.00	2.00	7.10	10.63
FRAME SIZE (EG)	L	M	O	P	T	KEY			KEYSEAT R	TERMINAL HOUSING		
						WIDTH	THICK	LENGTH		AB	AC	XB
6808B	42.13	29.33	33.93	36.22	12.21	1.250	1.250	10.00	4.169	40.30	31.40	23.80
FRAME SIZE (EG)	SHAFT EXTENSION			BEARINGS								
	N-W	U	V	DRIVE END	OPP. DRIVE END							
6808B	11.88	4.875	11.38	6326C3	6322C3							

- NOTE: 1. DIMENSION D TOLERANCE: +0.00inch, -0.06inch  
 2. DIMENSION U TOLERANCE: +0.000inch, -0.001inch  
 3. DIMENSION R TOLERANCE: +0.000inch, -0.015inch  
 4. DIMENSION V IS THE LENGTH OF STRAIGHT PART OF SHAFT  
 5. FOR DIRECT FLEXIBLE COUPLING